

SICHERHEITSSCHLEUSENGELÄNDER

TYP RB

TYP	RAUMBEDARF			
	LASTEN- HÖHE A	DECKEN- HÖHE B	SCHLEUSENGELÄNDER IN BETRIEB :	
			TIEFE C	ÜBERSTEHENDER TEIL D
RB1	1650	2100	2105	555
RB2	2000	2400	2225	675
RB3	2350	2650	2325	775

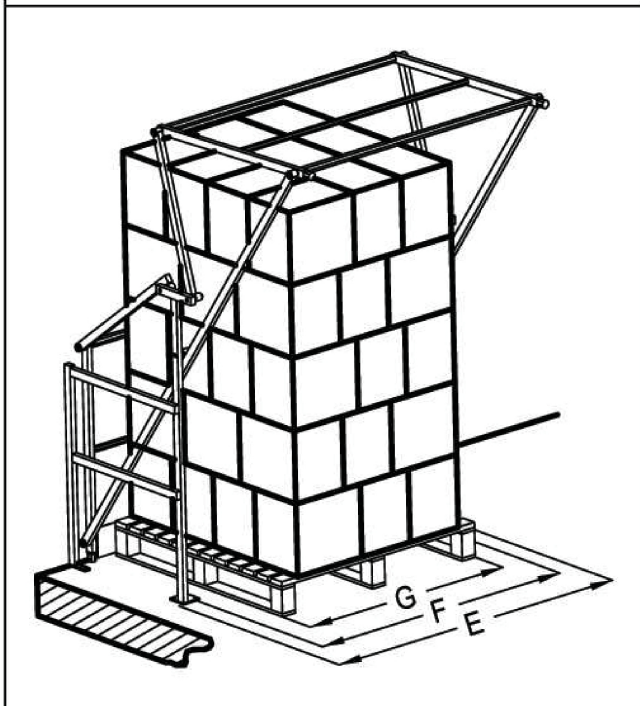
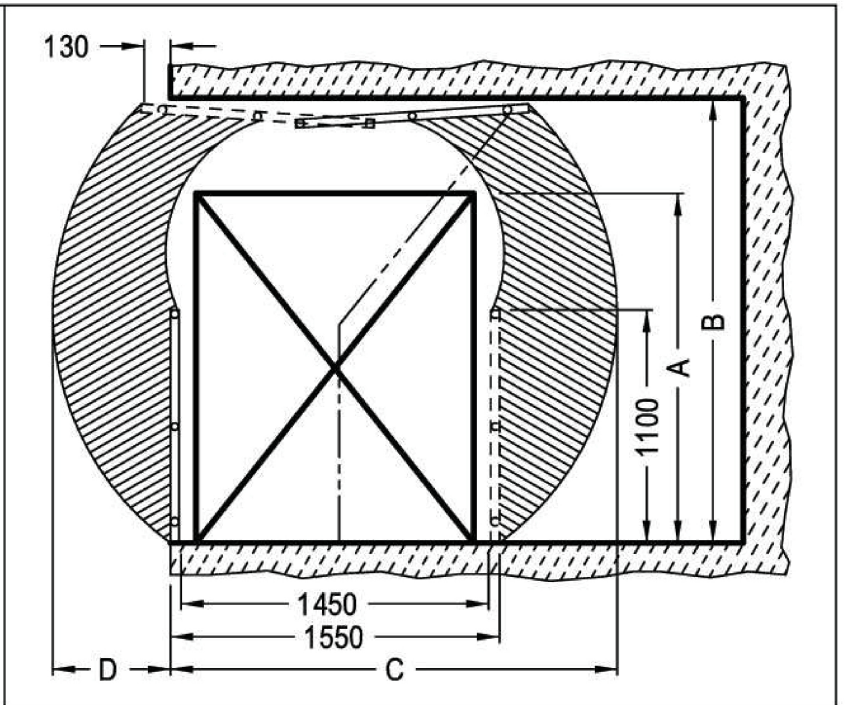
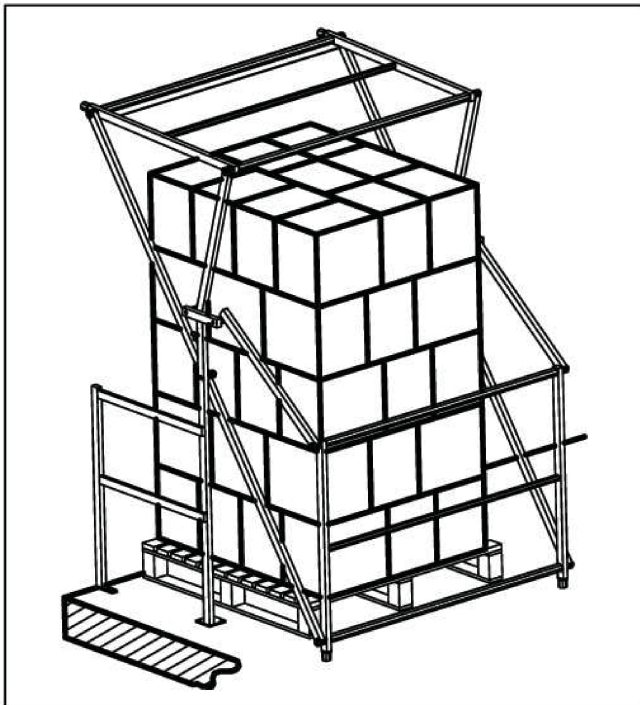

BAUBREITE E	MAXIMALE NUTZBREITE F	EMPFOHLENE BREITE DER LAST G
1700	1480	1200
2100	1880	1600
2500	2280	2000
3100	2880	2600